

**Abstract**

Making voice calls for faster information exchange is showing its increasing demands day by day. IP telephony is sensible in the view to provide such platform. IP telephony in heterogeneous network environments can prove its dominating characteristics while working on IP platform as compared with circuit switched network. Interface using SGGN gateway for IP telephony, to provide channel to all WiFi users to make voice calls to GPRS mobile user, can provide ultimate solution for the need. In the existing EPBX system this can be used as add-on feature. Data traffic on existing GPRS networks have proved reliability in terms of less delays and cheaper way of information exchange. At the same time VoIP on WiFi network is showing increasing demand for corporate VPNs today. Interconnecting these two will provide more reliable and single device-multi interface platform and add more flexibility to its users. Unlicensed mobile access using WiFi can provide such integration of different networks together. The analysis has been done by simulating unlicensed mobile access (UMA) on NS2. Analysis indicates that the system can perform better for maximum number of users with less end to end delays and optimum throughput.

**Keywords:** VoIP, WiFi, GPRS, EPBX, NS2, performance analysis.

**Introduction**

There is an emerging demand to have cheaper communication within a fixed range, like in an office or a township. Intercom is also a similar system but it has fixed phones connected by guided media. Centralized architectures with dumb terminals make exchange of data is very complex, but provide very limited functions. Closed and hardware proprietary systems hinder the enterprise in choosing products from different vendors and deploying a voice function to meet their business needs. The recent advancements in the mobile telephony have incorporated the features of accessing Wi-Fi from such a small device [1]. The presence of Wi-Fi in the latest mobiles allows the user to access the internet with the help of a Wi-Fi router. Exploiting the entire bandwidth of 2.4GHz for making voice calls between devices, it eliminates the need of using the service provider's bandwidth. Hence voice calls can be made at zero cost in unlicensed frequency band of own Wi-Fi network. Most of the latest models of phones come with Wi-Fi [2]. The number of people using Wi-Fi devices has been increasing and may even rise higher in upcoming days.

**Methodology**

Figure 1 indicates architecture of the system designed for UMA. The system satisfies the aim of

establishing the call from wifi mobile node from wifi region to gprs mobile node. SGSN can act as GSM gateway to provide GPRS connectivity to its mobile node.

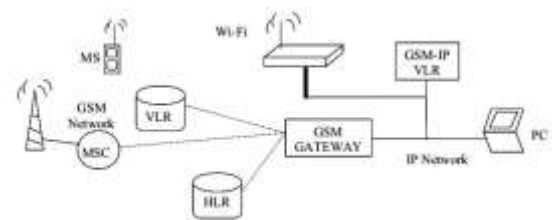

**Figure 1: Designed system architecture**

In IP based EPBX system we can call from any IP phone to any other IP phone within premises. The advancement further in this technique has shown that the call can be established from any IP phone to any other IP phone which is not in the same campus premises and even worldwide anywhere, by using broadband connection and gateways.

In our system the call can be established from wifi mobile node which is connected to IP network acting as backbone to provide internet connection. For GSM based mobile node the internet connection can be given by providing IP network interface via SGSN gateway.

For keeping identification of the device

calling GSM-IP VLR can be maintained which will keep table driven information of SIM number to IP bindings.

**Algorithm**

To establish the call from wifi to gprs mobile node in designed system architecture, we use the algorithm steps as indicated in figure 2.

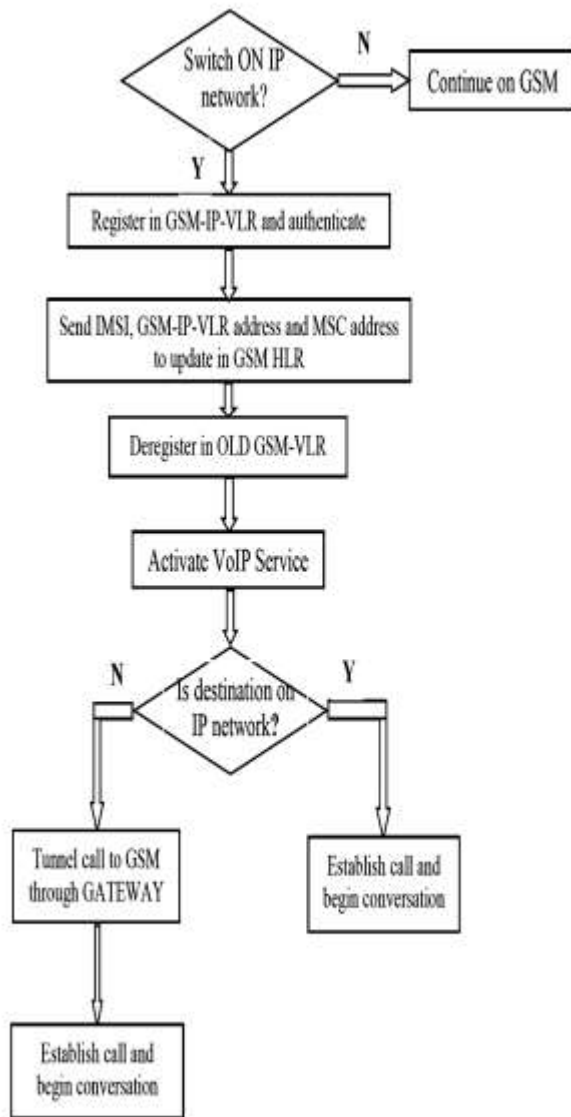
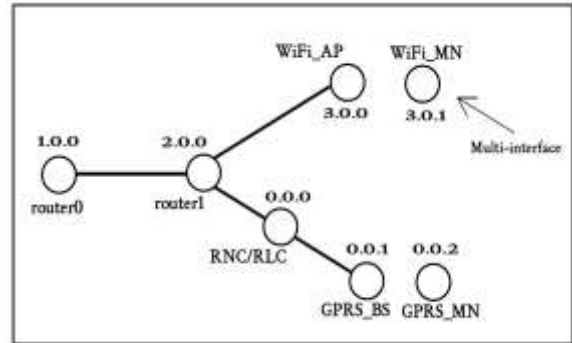

Figure2: Algorithms used to establish call

We consider mobile node is wifi enabled. When any mobile device comes in WiFi range it can switch its network to get connected on wifi. Otherwise it will work normally on existing gprs network.

**Simulation**

We implemented the designed architecture to analyze the performance of the network in NS2. Implementation of the topology is as indicated in figure3. It indicates the arrangement of nodes along with hierarchical addressing.



The RNC/RLC here is connected to router1. Router1 acts as SGSN gateway. Router0 to router1 connection indicates the normal Ethernet network. WiFi access point provides WiFi mobile users IP connectivity. WiFi MN(mobile node) call is connected to GPRS MN. We have configured all the necessary traffic generation conditions to make VoIP call. We analyse the throughput of the network for different traffic generation conditions.

**Results and discussion**

We have analysed the network throughput performance for different traffic generating capacities of the wifi mobile node. We consider the traffic in terms of packets per second. The trace file generated in ns2 can be analysed to check throughput performance. Following table indicates the observations taken for different conditions.

Tables:

Table 1. Observation of throughput analysis

Traffic (Packets per second)	Throughput (Kbps)
48	18.947368
122	120.000000
146	144.000000
158	153.496000
170	195.040000
195	81.210425
219	71.843482
244	64.693048
488	32.573273

**Graphs:**

We observe the table indicating throughput performance analysis by plotting the graph as insicated in figure 4.

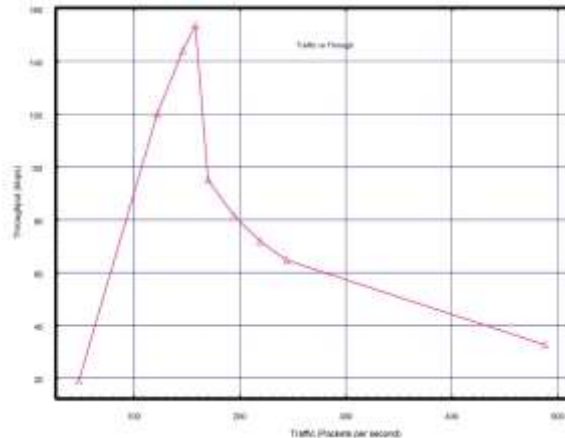

Figure 4: Graph of throughput performance

From the graph we observe that throughput increases with respect to traffic generated by node and afterpericular point it starts again decreasing. The traffic generation of upto 146 packets per second can give better performance in the network. Also we can add further the codec limitations to analyse the throughput offered. The traffic that can achieved for G.717 codec can be upto 50 packets per second[4]. We also observe that even if traffic is 50 packets per second it can give adequate throughput performance.

**Conclusion**

We implemented unlicensed mobile access using wifi concept and simulated different traffic conditions scenarios in NS2. Simulated results have shown that, as per requirements for better performance in IP telephony, IP telephony in WiFi to GPRS network as mentioned in UMA can be established and can provide cheaper alternative to todays circuit switched telephony.

GPRS network has maximum possible bandwidth of 160 kbps where as we get throughput of 144kbps at 146 packets per second data traffic generated by single node.

**References**

1. *Pintel Corp., Next Generation VoIP Services and Applications Using SIP and .Ja4a Technology Guide*, [http://www.pingtel.com/docs/collateral\\_techguide\\_final.pdf](http://www.pingtel.com/docs/collateral_techguide_final.pdf).

2. Venkatraman.S , Siddharth Natarajan and T.V. Padmavathi, "Voice Calls Over Wi-Fi", Vol I WCECS 2009, October 20-22, 2009, San Francisco, USA.
3. B. Metcalfe, " The Next Generation Internet ", IEEE Internet Computing, vol .4 p. 58 - 59, Jan- Feb ,2000.
4. Chian C. Ho, tzi-Chiang Tang, Chin-Ho Lee, Chih Ming Chen,HsinYang Tu,Chin-Sung Wu,Chao-His Chang,Chin-Meng Huan, "11.323 VoIP Telephone Implementation Embedding A Low Power SOC Processor",O7803-7749-4/03 IEEE.,p.163-166.
5. <http://www.umatechnology.org/overview>
6. [http://www.cisco.com/c/en/us/solutions/collateral/wireless/4400-series--wireless-lan-controllers/net\\_implementation\\_white\\_paper0900aecd804f1a46.html](http://www.cisco.com/c/en/us/solutions/collateral/wireless/4400-series--wireless-lan-controllers/net_implementation_white_paper0900aecd804f1a46.html)
7. <http://hilo.hawaii.edu/news/kalono/documents/kalono-apr13.pdf>
8. <http://www.cisco.com/cisco/web/solutions/small-business/resource-center/articles/serve-custome>
9. <http://www.protocols.com/pbook/pdf/voip.pdf>
10. [http://www.nist.gov/itl/antd/emntg/ssm\\_seamlessandsecure.cfm](http://www.nist.gov/itl/antd/emntg/ssm_seamlessandsecure.cfm)
11. [www.isi.edu/nsnam/ns/ns-contributed.html](http://www.isi.edu/nsnam/ns/ns-contributed.html): Richa Jain (GPRS patch for NS2)